

KB Hysteresekupplung - kompakte Bauweise

Hysteresis Coupling - compact design

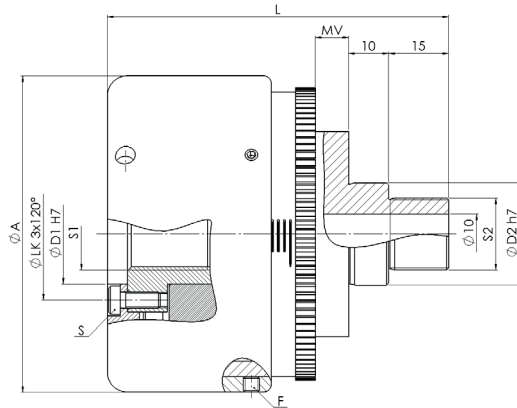

Material:
Edelstahl
Aluminium
Temperaturbereich:
0 °C bis +40 °C

Material:
Stainless steel
Aluminum
Temperature range:
0 °C to +40 °C

KB		Abmessungen Dimensions							
Größe Size	α TKN	b TKN	L	ØA	ØD1	S1 S2	ØD2	ØLK	MV
	[Nm]		[mm]						
1	0,2 - 1,2	0,05 - 0,5	70	73	18	M16x1,5	20	25	8
2	1 - 2,5	0,2 - 1,5	85,5	79	25	M18x1,5	25	33	10
4	1,6 - 4,2	0,5 - 2,8	85,5	105	30	M24x1,5	30	48	10
8	4 - 8	2 - 6	105	115	30	M24x1,5	30	48	14
12	3 - 12	2,5 - 10	105,5	130	35	M24x1,5	30	46	15

KB		ISO 4762	ISO 4029	Technische Daten Technical Data								
Größe Size	α TKN	b TKN	S	F	TA (S)	TA (F)	PV	F _{rad}	F _{ax}	J _A	J _I	M
	[Nm]				[Nm]		[W]	[N]		[kg cm ²]		[kg]
1	0,2 - 1,2	0,05 - 0,5	M3	M4	2	1,5	20	200	150	3,6	1,3	0,8
2	1 - 2,5	0,2 - 1,5	M4	M4	5	1,5	30	300	200	6,2	2,5	1,2
4	1,6 - 4,2	0,5 - 2,8	M4	M5	5	2	40	400	250	16,2	7,9	2,1
8	4 - 8	2 - 6	M4	M5	5	2	45	400	250	25,6	10,5	4,8
12	3 - 12	2,5 - 10	M4	M5	5	2	50	500	275	41,2	15,3	4,9

Laufend aktualisierte Daten finden Sie auf unserer Homepage. For continuously updated data please refer to our website.

Technische Daten	Technical Data
TKN - Drehmoment	TKN - Torque
TA - Anziehmoment der Schraube	TA - Installation torque per screw
PV - max. Verlustleistung	PV - max. power loss
F _{rad} - zulässige Kräftebelastung radial	F _{rad} - Permissible force load radial
F _{ax} - zulässige Kräftebelastung axial	F _{ax} - Permissible force load axial
J _A - Massenträgheitsmoment des Außenrotors	J _A - Mass moment of inertia of the outer rotor
J _I - Massenträgheitsmoment des Innenrotors	J _I - Mass moment of inertia of the inner rotor
M - Masse	M - Mass

Bestellbeispiel / order example	KB	4	α	SX
Modell / model				
Größe / size				
Drehmomentbereich / torque range				
Sonderoption / special option				

