

# SWK/B-BB mit Konus-Klemmnabe with conical clamping hub

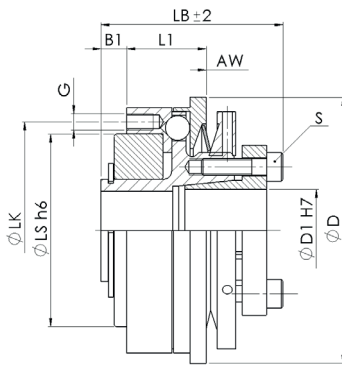

Version B

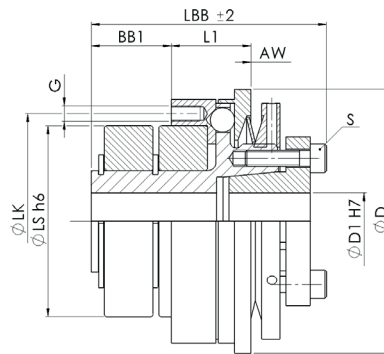

Version BB

**Material:**  
Stahl  
**Temperaturbereich:**  
-30 °C bis +120 °C  
**Optional Passfedernut ØD1:**  
Nach DIN 6885  
**Schaltart:**  
Synchronausführung  
Optional: Durchrastausführung

**Material:**  
Steel  
**Temperature range:**  
-30 °C to +120 °C  
**Optional keyway ØD1:**  
Acc. to DIN 6885  
**Winding connection:**  
Synchronous version  
Optional:  
Multi-position re-engagement version

SWK/B   SWK/BB		Abmessungen Dimensions											ISO 4762	Technische Daten Technical Data					
Größe Size	1 TKN	2 TKN	LB	LBB	ØD	ØD1	ØLS	ØLK	L1	B1	BB1	AW	G	S	TA	J	n <sub>max</sub>	M (B)	M (BB)
	[Nm]		[mm]												[Nm]	[kg cm <sup>2</sup> ]	[min <sup>-1</sup> ]	[kg]	
10	2 - 5	5 - 10	36,5	47,5	50	5 - 16	37	42	16	5	16	0,8	6x M3	M4	5	1	11800	0,25	0,45
30	5 - 15	10 - 30	44,5	58	65	9 - 20	47	53	19	6	20	1,2	6x M4	M4	5	3	9200	0,45	0,55
60	15 - 35	20 - 60	60	78	80	12 - 25	62	69	26	8	26	1,2	6x M5	M6	19	6	7600	1,2	1,32
80	15 - 40	30 - 80	60,5	78	95	15 - 35	68	80	28	10	27	1,8	6x M6	M6	19	16	6200	1,4	1,8
150	25 - 75	65 - 150	60,5	78	95	15 - 35	68	80	28	10	27	1,8	6x M6	M6	19	16	5800	1,4	1,8
200	50 - 140	100 - 200	68	86	110	20 - 42	80	90	30,5	10	28	1,8	6x M6	M6	19	26	5300	1,8	2,1
300	70 - 160	150 - 300	76	96	120	25 - 46	90	102	35	10	30	1,8	6x M8	M8	42	39	4800	2,6	3
500	80 - 250	200 - 500	76	96	130	30 - 50	100	112	34	10	30	1,8	6x M8	M8	42	80	4550	3,8	4,4
800	260 - 600	500 - 800	117	139	170	40 - 60	110	125	51	15	37	2	6x M12	M16	360	275	3400	11	12,3
1300	450 - 900	800 - 1300	117	139	170	40 - 60	110	125	51	15	37	2	6x M12	M16	360	275	3400	11	12,3
1600	500 - 1000	900 - 1600	125	152	195	50 - 90	150	168	60	19	46	2	6x M12	M12	145	320	3050	12	13,5

Massenträgheitsmoment und Masse sind mit dem größten Bohrungsdurchmesser gerechnet. Mass moment of inertia and mass are calculated with reference to the largest bore size. Laufend aktualisierte Daten finden Sie auf unserer Homepage. For continuously updated data please refer to our website.

### Technische Daten

TKN - Drehmoment  
AW - Ausrückweg  
TA - Anzugs-Drehmoment der Schraube  
J - Massenträgheitsmoment  
n<sub>max</sub> - max. Drehzahl  
M - Masse

### Technical Data

TKN - Torque  
AW - Disengaging travel  
TA - Installation torque per screw  
J - Mass moment of inertia  
n<sub>max</sub> - max. speed  
M - Mass

Bestellbeispiel / order example **SWK/B 30 14 10Nm 1 SX**

Modell / model	
Größe / size	
Bohrung ØD1 H7 / bore ØD1 H7	
Ausrückmoment / disengaging torque	
Drehmomentbereich / torque range	
Sonderoption / special option	

