

WSR220-RF selbstzentrierend - Edelstahlausführung self-centering - stainless steel version

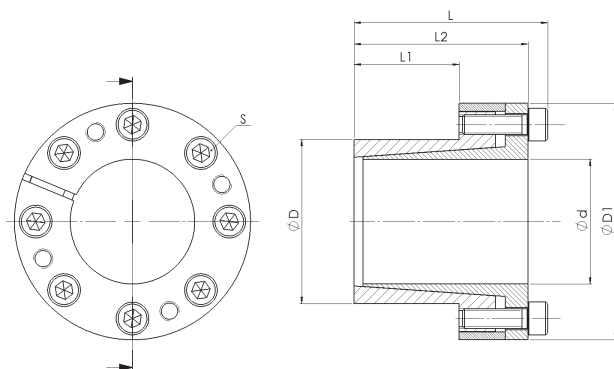

Material:
Edelstahl
Toleranz:
Welle: h7
Nabe: H8
Oberflächenrauigkeit:
Rt max. 3,2 µm

Material:
Stainless steel
Tolerance:
Shaft: h7
Hub: H8
Surface roughness:
Rt max. 3,2 µm

WSR220-RF		Abmessungen Dimensions				Flächenpressung Surface pressure		ISO 4762 - A4-80		
Ød x ØD	TKN	L	L1	L2	ØD1	P _w	P _N	S	TA	M
	[Nm]	[mm]				[N/mm ²]			[Nm]	[kg]
10x16	22	31	14	27	29	82	51	4x M4	2,4	0,06
11x18	24	32	14	28	32	75	46	4x M4	2,4	0,06
12x18	26	32	14	28	32	69	46	4x M4	2,4	0,09
14x23	30	32	14	28	38	59	36	4x M4	2,4	0,12
15x24	73	43	16	37	44	107	67	3x M6	8	0,15
16x24	78	43	16	37	44	101	67	3x M6	8	0,2
18x26	87	45	18	39	47	79	55	4x M6	8	0,25
19x27	92	45	18	39	49	75	53	4x M6	8	0,25
20x28	97	45	18	39	50	71	51	4x M6	8	0,25
22x32	105	52	25	46	54	47	32	5x M6	8	0,35
24x34	175	52	25	46	56	64	45	5x M6	8	0,35
25x34	180	52	25	46	56	62	45	5x M6	8	0,35
28x39	200	52	25	46	61	55	40	5x M6	8	0,44
30x41	220	52	25	46	62	51	38	6x M6	8	0,45
32x43	310	52	25	46	65	64	46	6x M6	8	0,5
35x47	340	59	32	53	66	46	34	8x M6	8	0,55
38x50	370	59	32	53	72	42	32	8x M6	8	0,6
40x53	390	59	32	53	75	40	30	9x M6	8	0,7
42x55	410	59	32	53	78	39	29	9x M6	8	1
45x59	820	78	45	70	86	48	36	10x M8	22	1,15
48x62	880	78	45	70	87	45	35	10x M8	22	1,2
50x65	910	78	45	70	92	43	33	10x M8	22	1,3

Laufend aktualisierte Daten finden Sie auf unserer Homepage. For continuously updated data please refer to our website.

Technische Daten

TKN - Drehmoment
P_w - Flächenpressung Welle
P_N - Flächenpressung Nabe
TA - Anzugs-Drehmoment der Schraube
M - Masse

Technical Data

TKN - Torque
P_w - Surface pressure shaft
P_N - Surface pressure hub
TA - Installation torque per screw
M - Mass

Bestellbeispiel / order example	WSR220-RF	28	x	39
Modell / model				
Ød				
ØD				

